



# **THE COUNTY LINE** **ROADRUNNER**

*Published Monthly by the Mobile Amateur Radio Awards Club, Inc.*



**Volume XLIII**

**December 2013**

**Number 12**

## **Riding the County Lion**

**Dave – KE3VV**

The County Lion reminded me that it is time for another Roadrunner column, and just because my arms and right shoulder are sore is no excuse to delay another day. The Lion is eager for me to get on with preparations for my trip to Kenya in January. He says he has relatives there, but I am sure that Kenya has provinces and districts - but no counties – so they must be his more “provincial” relatives. I guess I didn’t realize just how many immunizations are needed for a trip to Africa – even the not-so-darkest parts. I finished up my yellow fever and typhoid (which are “attenuated” live vaccines that still leave you a bit “plooky” for a few days). This morning was not so bad – the final hepatitis A and B combo in one arm and the bonus bundle of DPT (diphtheria-pertussis-tetanus) in the other. All that after a one-hour session of physical therapy for the rotator cuff makes for a bit of soreness. The Big Green Dragon suggests strong drink, but it is barely noon... and there is this column, which is probably better written at least half sober (although I am told it is better read after a few stiff snorts).

I guess I shouldn’t complain too loudly – after all, I did wake up on the green side again this morning, which is always a bonus. Having celebrated 68 years on the green side on Thanksgiving Day, I know I have that and a lot more to be grateful for (or “for which to be grateful” for all the English majors and grammar aficionados). I know I will miss working Ed (N4UJK) and Ernie (W7KQZ) and some of my other usual road trip contacts this time. It is always tough to hear about another Silent Key among the ranks of county hunters, and this has been a year of reflection on the importance of friends and making the most of the time we have on the road and on the radio.

### **Contents**

Ballott Recognition	6
Calendar	16
Dateline CW	3
Digital Happenings	7
History Happens	5
MARAC National	18
Report Notes	4
Riding the County Lion	1
Treasurer’s Report (W0NAC)	17
WA4EEZ	19

I am headed off for Florida later this week to attend a board meeting of the Coral Restoration Foundation in Key Largo and spend a few days with Mom in Venice over on the Gulf coast. Lord willin' and the creek don't rise, I plan to put out some counties in the Sunshine State, although not as many as I would like. The County Lion wants to take a sojourn north into Pennsylvania and New York later this month, so that would be a possibility for some road trip transmissions. I am getting very close to finishing all of the required 500 transmits for Master Platinum, so a couple dozen new ones would be good. Down under 100 counties to go for 8<sup>th</sup> time too (and closing in on USA-CW II as well), so lots of fun on the radio.

There have been a lot of Iowa counties being run lately, and it has been an absolute delight hearing all of the correct pronunciations of county names. Although for Iowa, that really isn't a major challenge – except for a few. Allamakee gets butchered a lot, but mostly by folks who don't realize that the big accent goes on the last syllable – Al-a-ma-KEY. There is always a bit of confusion over counties spelled Buena Vista... a tendency to pronounce them all the same as if they were Spanish, which is actually only correct in New Mexico. In Iowa (and the town in Virginia), Buena Vista is pronounced with a long "u" (and a "y" sound after the initial "b"), so it comes out correctly as "bYOU-na Vis-ta). Who Gnu? As they say in Africa.

It has been a long time since I heard anyone mispronounce Des Moines (no "s" sounds – the County Lion says they are called "sibilants") – although it might be fun to hear Dez Moynez once in a while, I doubt the natives would be amused. Neither Keokuk (Key-oh-cook) nor Kossuth (Co-**SOOTH**) seem to give any county hunters trouble, nor do Poweshiek (**POW**-eh-sheek) or Sioux (**SUE** – just like the native American lawyers pronounce it) or Tama (**TAY**- mah). But you could probably win a few shekels betting someone on the correct way to pronounce Wapello County. Most folks – even some of the most seasoned Iowa travelers persist on putting the emphasis on the first syllable (WOP-hello). Nope! Wrong! It is wah-**PELL**-oh. Who knew? The County Lion swears he has always said it right. Hah!

In any event, it is more fun to run them and work them than get too worked up about how to say them – or spell them if you are a spotter – but I always like to get the hard ones right when I stop for gas or a sandwich - makes the local folks think you appreciate them a bit more. More on this topic as the New Year arrives and evolves. The Big Green Dragon reminds me that we are heading into 2014 very soon and that means more road trips and counties and awards and fun places to go and be. Maybe even some visits to a Waffle House or two where I haven't eaten yet or some other exotic places. In any event, the Dragon, the Lion, and I wish you a most merry and peaceful and enjoyable holiday season and the very best 73's and 88's.



**Dateline CW**

Ed, KN4Y

## Since county hunters learned mobile, no county is safe.

I put the last ornament on the Christmas tree as Gator slides to a stop at the recycled railroad tie. Gator enters smelling like ethanol. I ask, "Hi Gator did you take a bath in your elixir?" "No Dude, a product drum ran over as I walked by column A take off. Is it really bad?" I hold my nose, "No, but don't go near the Senior Center." Gator ignores me, "Neat Christmas tree. What are those paper cylinders hanging from the limbs?" "I call it my county hunters Christmas tree, the cylinders are rolled up county maps I used for the Christmas tree ornaments and you will notice I used different colored paper." Gator shakes his head and opens a white cardboard box container, "Here have a latte, it is obvious you need caffeine. By the way how did you do in the ARRL Sweepstakes?"

I hand Gator a memory stick, "Here is the sweepstakes log from the laptop, see what I did. By the way KC3X, W4SIG, and W7FEN were out on Halloween trick or treating mobile." Gator is not paying attention as he sits in the office chair and turns on the computer. I sip my latte and hope nothing sparks. Gator sips his latte, "I see you made 260 QSO's and got two new counties on 10-meters, Last County in Utah on 40-meters, one new county on 80-meters and your last 1x2 call in Arizona. Not bad for a weekend. What are you going to do with the log?" "I will send the log into the ARRL and give the points to the Florida Contest Group." Gator reaches into his pocket, "Here Dude you can use this." He hands me a small spray bottle, "It is hand sanitizer to help you send clean code." We both have a good laugh; I don't think Gator was serious.

I hand Gator another memory stick, "Check out the OK-OM contest and the Kentucky QSO party logs. I drink my latte as Gator plays with the mouse, "Well Dude you made 75 QSO's with the Czech and Slovak radio guys and worked 71 districts, is this good?" "Not really, there are over 150 districts, making a sweep unlikely. Many of these stations will QSL and I get a chance to introduce the fun of county hunting." "Great idea, but you only made 20 QSO,s in the Kentucky QSO party, but it was effective with 3 No-star, 3 counties on 80-meters and 1 QSO on 160-meters. Why the low numbers?" I eat a cookie that fell off the computer, "I listened and I heard little Kentucky activity on CW. If it were not for K5YAA running mobile amuck in Kentucky my QSO party total would need Obama care.

By the way, I almost forgot the Bulgarian guys had a LZ CW DX Contest; the log is on the memory stick." Gator opens the log, "Not bad Dude. You made 100 QSO's." "Yes that was my goal." "Why?" Gator asks. "Many of the operators also work me when mobile in a QSO party, so I returned the favor." "I see you made 229 QSO's in the CQ WW CW Contest all on ten meters. Did you forget how to turn the band switch?"

Suddenly we hear Gators cell phone, "Sorry Dude I have to move on out. There is a problem with the temperature sensor on column C". He is gone like a pure thought and I hear him yell, it takes many nails to build a crib but... He is out of my hearing range, I shut the door. The printer starts and I get the printout, it is the list of mobiles heard during November on the CW county hunters call frequencies.

I read: KC3X, K2HVN, K4YT, K5YAA, K9JWV, KA4RRU, KC7YE, KO1U, KO7X, KS5A, KW1DX,

N4AAT, N4JT, N9QS, NF0N, NS5J, NT2A, W0EAR, W0NAC, W3DQT, W4SIG, W7FEN, WA4UNS, WB0PYF, and WG9A,

Extra time is scarce during the holiday season and if time is found, there are many CW contests planned. The ARRL has the 160-meter CW contest and the 10-meter CW/Phone contest. This is a way to get some needed counties on these bands. There are no State QSO parties this month but there is the Great Colorado Snowshoe Run, a CW QRP activity. QRP is an abbreviation for hog hunting with a slingshot. If you like multiple mode operation try the Iron Man contest. Ending the month is the Stew Perry Top Band Distance Challenge on 160-meters., another activity to increase county totals on the top band. Remember in a CW contest you may not be fast and not slow, but even being half fast is an adventure. Nap Time.

MERRY CHRISTMAS AND A 3077 COUNTY NEW YEAR.



### **Report Notes**

There were no new members to report last month.

Awards, Birthdays and the Award Manager's Report will not be issued this month due to Bob's (KV6AWK) vacation cruises.

Ed.

**History Happens**

Gary, K4EXT

I continue to be amazed ... 14 different people submitted pictures to the County Sign Project during the first 25 days of November. Some of the folks were new to C/L pics ... others were repeat CH'ers. A big-time WOW and a big-time THANKS from me! Only 953 counties to go now for "Pictured All Counties" ... will be interesting to see how close to 3077 this project gets.

Check out the latest collection of pictures and information by visiting the CH History/Archive website at the following address:

**<http://www.CHarchive.com>**

Bob, N8KIE finally got a picture of the Oakland, Michigan county line for me. I can't remember how many times I bugged him to get a pic of his home county for me. Recently, he even tried to talk Jim, WY8I into driving over from Saint Clair county to get the Oakland county sign picture. Geez ...

Bob has been glued to his radio working counties for his 6th star as well as collecting stars for that new-fangled Star-XX Award. Fact is, if you hear Bob say "I filled another bucket" ... that means he just finished working his 20th star for a given county ... even though some of us in the chat room like to challenge him with other meanings for that phrase.

By the time you read this column, Bob and XYL Jaci will be on their annual winter vacation to Honolulu, Hawaii. So no more 6th time counties for a while. And no more buckets of stars for a while either. But at least I got my Oakland County picture!



**Ballot Recognition**  
***2nd Quarter 2013***

I would like to congratulate the following stations for receiving recognition and votes from their peers in the 2<sup>nd</sup> quarter award voting. There is no particular order, but all have received at least 3 points. 2 points are given for a first place vote and 1 point for a second place vote. I received 24 electronic ballots.

**Second quarter results**

**NET CONTROL SSB:** N5UZW, AB7NK, KZ2P, KA1JPR, KC3X

**NET CONTROL CW:** K0DEQ, N4CD, W0GXQ, KC3X

**BEST MOBILE SSB:** N8KIE, W4SIG, AF3X, WA4UNS, K2HVN, N0KV, N9QS

**BEST MOBILE CW:** W0GXQ, N4CD, K2HVN, N0KV, W5QP, K5YAA

**BEST TEAM:** N0KV/N0DXE, KB0BA/N0XYL, AA9JJ/N9QPQ, KJ5PQ/KG5UZ

**Kent Reinke, KV7N**  
**MARAC Election Coordinator**  
1826 E 4500 N  
Buhl, Idaho 83316



**Digital Happenings****Digital Happenings #16****(November 2013)****By W0NAC ("Matt")**

Because of the holiday season and other things I need to do, this month's article will be a bit shorter than past articles. (Maybe you are saying "That's a good thing!") However, I will follow through this month on describing the rest of my experiences installing our rig in the new Volkswagen Passat TDI Diesel. It is still my hope that having a better understanding of the process will encourage some of you to go ahead and install (and operate!) a digital mobile station. Also, for the time being, there will be no new puzzles issued. Starting next month the Challenge Department will go away.

**Challenge Department:**

Last month I challenged you to solve the following puzzle:

**"Crossing a Rickety Bridge at Night by Flashlight"**

**A group of four people (Annie, Bob, Carl, and Deral) need to cross a bridge. It is dark and they must light their path with a flashlight. No more than two people can cross the bridge simultaneously, and the entire group has only one flashlight. Different people take different times to cross the bridge and the slowest person in any group determines the time to cross.**

**Annie can cross the bridge in 1 minute**

**Bob can cross the bridge in 2 minutes**

**Carl takes 5 minutes to cross the bridge**

**Deral is the slow poke! It takes him 10 minutes to cross the bridge**

**How can the entire group make it to the other side of the bridge in 17 minutes maximum?**

Two people submitted solutions this month (in the order given below).

1 - KB9VQM – Louie (Correct with 17 minutes total)

2 - W2CC – Dave (Correct with 17 minutes total)

There are 2 correct solutions for this puzzle as follows:

**Solution A**

<b><u>Step</u></b>	<b><u>Action</u></b>	<b><u>Minutes Required</u></b>	<b><u>Total Elapsed Time</u></b>
0	(Start)	0	0
1	Annie & Bob Cross Together	2	2
2	Bob Returns	2	4
3	Carl & Deral Cross Together	10	14
4	Annie Returns	1	15
5	Annie & Bob Cross Together	2	17 (All are now on the other side)

**Solution B**

<u>Step</u>	<u>Action</u>	<u>Minutes Required</u>	<u>Total Elapsed Time</u>
0	(Start)	0	0
1	Annie & Bob Cross Together	2	2
2	Annie Returns	1	3
3	Carl & Deral Cross Together	10	13
4	Bob Returns	2	15
5	Annie & Bob Cross Together	2	17 (All are now on the other side)

You will note that the only differences between these solutions are in steps 2 and 4.

### **STORY OF WONAC'S NEW MOBILE INSTALLATION (CONTINUED)**

Please let me reiterate that this is not intended to be a complete "How To" book on mobile installation. I will only be hitting high points. Also, this story contains a lot of personal opinion based on many years of experience.

Last month, I covered the following topics at some length:

- 1) PICKING THE VEHICLE**
- 2) INSTALLATION SO FAR**

Now for the rest of the story:

#### **3) INSTALLATION CONTINUED**

When the trailer hitch came in, I had the dealer install it. Since I was planning to use it primarily as an antenna mount, I insisted that they install it with stainless steel hardware and special serrated washers that would "bite" through any paint on the hitch.

I purchased a new receiver extension with several inches rise plus a simple extension so that the trunk lid will clear the antenna as it opens. The ball mounting hole had to be enlarged to 1.0 inches to accommodate the remaining parts of my mount. The extensions were then secured by heavy duty stainless bolts. Since the extension parts are coated with paint (an insulator), they would not make good electrical connections to the grounded hitch, so I added 2 heavy duty cables between the antenna mount and the trailer hitch mounting bolts which effectively bypassed the open circuits between the extension parts. **Tip: It is essential that you have a "good" ground connection between your antenna base and the car's body because the entire car is the other half of your antenna!** You can see the details of this arrangement on our car in the photos below.

**Trailer Hitch Grounding**

**Bottom Of Antenna Mount**





I then installed the rest of the antenna (which must be insulated from the base) through the 1.0 inch hole in the receiver extension using a special plastic insulator that was “printed” by a friend using his new 3D Printer. The antenna is still the same hybrid design with standard linear resonators at the top of the mast for the 80M, 40M, 30M, and 20M bands. “Flying Saucer” resonators (design by W9UCW) are spaced down the mast for 17M, 15M, 12M, and 10M. It is guyed using mono-filament line attached to heavy duty metal cup holders glued to the rear window of the car.

**Top Of Antenna Mount (Looking Down)**

**Upper Antenna With Resonators (Looking Up)**



After I finished installing the antenna, I took the car to Car Toys to complete the wiring. This turned out to be a rather “monumental” job that took 3 days and cost over \$1000 in labor. Even though it was expensive, I am very pleased with the result. At my age (81) I am no longer physically able to do what was needed and don’t have the special tools required to remove and re-install body panels or the skills to safely work around air bags.

I gave the installer a hand drawn sketch which showed how each item of equipment interconnected. By following this sketch plus occasional "hands on" instruction, the installer was able to complete the job with a minimum number of problems. Recently, I have converted this sketch into a vector graphics chart by using a free software program called "Draw Plus" by Serif. This is a great piece of software and if you need software to create professional looking charts, I highly recommend it. Here is the final result:

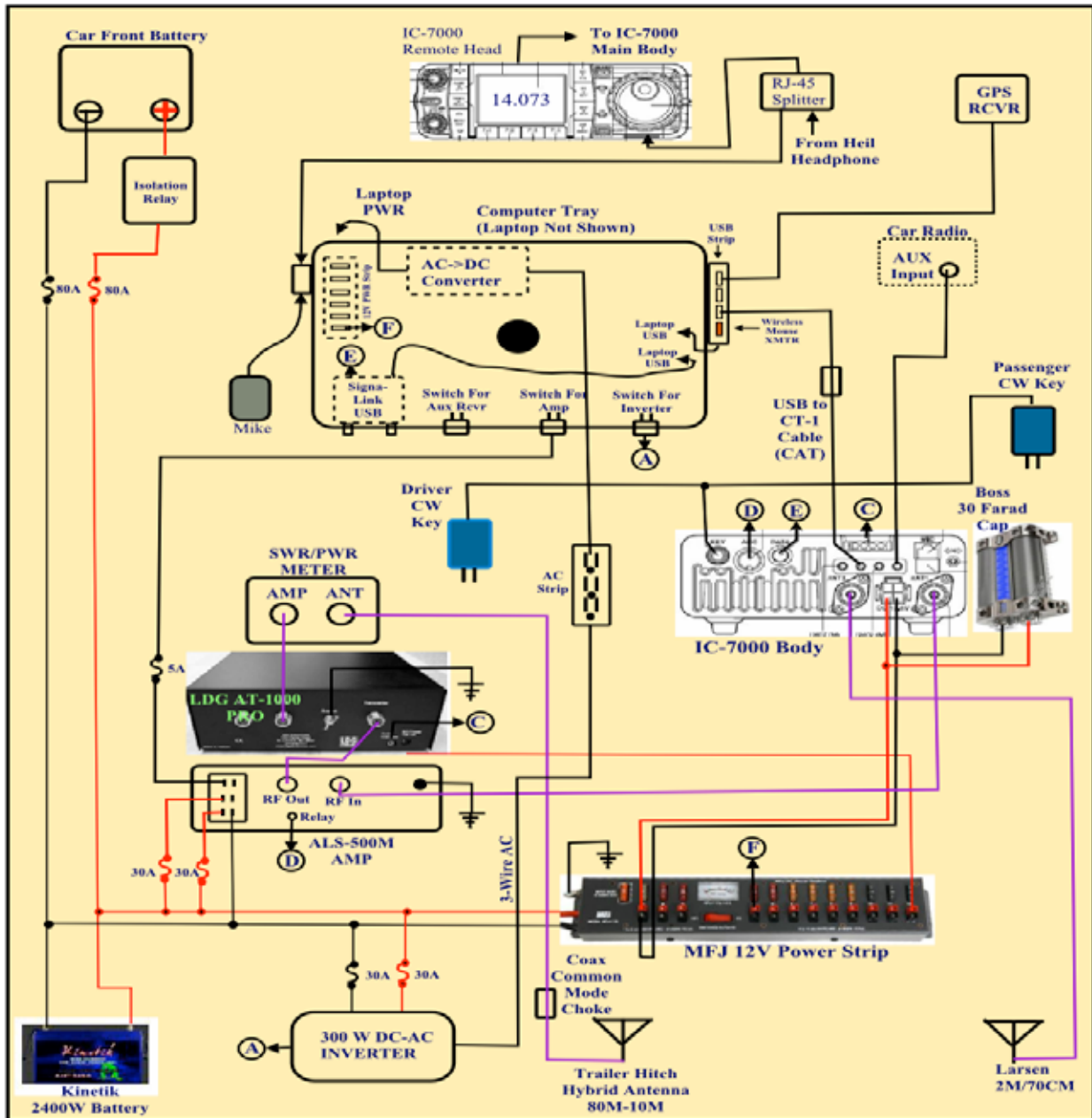

When looking at this chart, there are several things you should note:

- 1) This chart shows very roughly where the various items of equipment are physically located in the car.
- 2) Some wiring (particularly underneath the laptop tray) is not shown.
- 3) Some items of equipment (Heil headset/mike, auxilliary transceiver, radar detector) and their connections are not shown.
- 4) Every individual wire and every pin is not shown.

- 5) Some of the connections are individual wires and others are multi-wire cables or coax.
- 6) Connector pins are not necessarily shown exactly as they really are, but stylistically.

All of this was done to simplify the chart. It would have been overly complex and impossible to depict on a single drawing otherwise.

#### **4) INSTALLATION PROBLEMS**

Overall, the installer did a great job! However, he did make 2 errors – one rather minor, and the other serious. He managed to get the wires crossed on Sharon’s CW key so that dots and dashes were reversed on her paddle. This I managed to fix rather easily with a splice in the cable.

The serious problem was that when he went looking for a powered lead to tap into for the radar detector, he apparently tapped into a critical computer lead which totally killed the keyless start system. When I arrived to take delivery of the car, I discovered that there was absolutely no way to start the engine and had to leave it with Car Toys for another day. After much effort (unpaid of course), he finally discovered the root of the problem and connected the radar detector to another source of power and all was well.

#### **4) HOW DOES IT WORK?**

In a word – ABSOLUTELY GREAT!

The car itself and all installed equipment are totally quiet. No random noise, no hash, no “birdies”, no ignition noise, no alternator whine, NOTHING! Naturally, Mother Nature still generates her share of RF background noise, but with DSP filters, etc. this can be minimized. We can now copy “22” signals while moving down the road and no longer need to pull over and shut the engine off to take relays. Hooray!

Most people are not aware of other EMC problems where, especially when using high power, your own RF signal is so strong that it can disrupt proper functioning of the car’s computer(s) causing engine lights to come on or even cause the engine to lose power or stall out! I have experienced all of these problems at various times in the past. Also, the car computer’s sensitivity to your own signal can’t be tested in advance. You must wait until after your installation is complete to find out if you have an EMC problem. Fortunately, the Passat operates without a glitch with the linear putting out over 300 watts on all bands (200W max on 30M). **Tip: To help avoid EMC problems in your car, feed your mobile antenna with a longer piece of coax than needed so that you can coil up several turns of coax near the antenna feed point and clamp on 2 or more large ferrite beads (enclosing all turns) to create a common mode filter. This will help keep RF from flowing on the outside of the coax.**

Mechanically, the Passat is much quieter than most of the other cars I have had and it also rides better. In addition, feeding audio from the IC-7000 directly into the car’s audio system “AUX” input works nicely and yields great sound. The only glitch is that the Passat with keyless ignition has no accessory position to run the radio and sound system when the engine is stopped. The radio and audio system can be activated with the ignition off, but you have to do this manually by turning the radio power switch ON. Unfortunately, after about 30 minutes, the radio automatically turns itself OFF. This could happen in the middle of a long run if sitting on a county line. Fortunately, you can immediately turn it back on and start another 30 minute timeout cycle, but you will lose all audio for a few seconds, perhaps at a critical time.

#### **FINAL COMMENTS ON THIS INSTALLATION**

Admittedly, the rig setup described here is complex and contains a lot more equipment than is really needed for digital county hunting. For example, the linear amplifier is definitely “over-kill” for digital operations. If you only wish to operate on 30 Meters or higher in frequency, the tuner can probably be eliminated. For strictly digital ops, no CW keys are needed. Also, the 12V power distribution can be greatly simplified by eliminating the extra battery.

The only truly essential items are a laptop computer (with digital software), a transceiver (with antennas for the bands you wish to operate on), and an interface unit. All the other equipment was added for a variety of reasons such as expanded band coverage using all modes, better signal on SSB and CW, simplified band changing, or just plain operator

convenience. Please don't let the complexity of this setup scare you away from even trying to put together a digital rig of your own. Also, if you already operate a mobile rig on SSB or CW, the only additional equipment you need to go digital is a laptop computer (with software) and an interface box.

**FUTURE TRIP PLANS**

Sharon and I will soon be going on our "maiden voyage" with the new Passat and rig. We are thinking about a 3 day trip putting out (digital of course) counties in the panhandle of Texas and/or counties in southern Oklahoma. This trip may happen in late December if Sharon recovers soon enough from carpal tunnel surgery on December 4<sup>th</sup>. I will publicize our detailed plan as far in advance as I can both by direct email and in "Planned Trips" on the K3IMC web site.

**November Activities:**

Digital activities during November were even lower than in October. The only digital stations spotted on W6RK were:

11/12	W0NAC	Douglas, CO	PSK-63, RTTY-45
11/17	W0NAC	Arapahoe, CO	PSK-63, RTTY-45, DOMINO-22
11/25	KH6/G4KHG	Kauai, HI	Spotted on 14.070 – PSK-31??

There were probably other digital stations out there (maybe working state QSO parties or other contests?), but they were not spotted on W6RK.

There were several support calls related to digital setup, etc. in November. Maybe this article will inspire some new people to call. If you would like some help getting started with digital operations, just email me at [w0nac@comcast.net](mailto:w0nac@comcast.net) or call me any time at 303-799-3658. If you need someone to make test digital contacts with, I am also willing and able to do that.

The updated Table 3 is given below:

Table 3 - Active Digital County Hunters Award Status

#	CALL	NAME	STATUS* (M,F,I)	USA - DIGITAL Counties (of 3077)	(1 MODE)	(2 MODES)	FIVE MODE COUNTIES (3 MODES)	(4 MODES)	(5 MODES)	TOTAL	% 5-Mode Completed	LAST UPDATED
1	AA8R	Randv	F	1000+	-	-	-	-	-	0	0.0%	9/30/2012
2	AC0B	Cliff	F	205	-	-	-	-	-	0	0.0%	12/10/2012
3	AD1C	Jim	F	-	-	-	-	-	-	0	0.0%	
4	KODEQ	Bill	F	-	-	-	-	-	-	0	0.0%	
5	KOPVW	Rob	F	-	-	-	-	-	-	0	0.0%	
6	KOWJ	Lou	F	-	-	-	-	-	-	0	0.0%	
7	K4PBX	Jim	F	136	2903	121	7	2	0	3033	19.7%	11/12/2013
8	K5GE	Gene	F	26	1893	575	8	0	0	2476	16.1%	5/26/2013
9	K5SF	Dick	F	-	-	-	-	-	-	0	0.0%	
10	K5WAF	Bill	F	599	3044	?	?	?	?	3044	19.8%	5/2/2013
11	K7REL	Tom	F	-	-	-	-	-	-	0	0.0%	
12	K8OWY	Ed	F	-	-	-	-	-	-	0	0.0%	
13	K8ZZ	Ed	F	-	-	-	-	-	-	0	0.0%	
14	KA4RRU	Mike	F	774	3077	2902	749	40	1	6769	44.0%	10/31/2013
15	KA8JQP	Pamela	M/F	22	202	64	53	28	4	351	2.3%	9/12/2013
16	KC3X	Hollis	F	-	-	-	-	-	-	0	0.0%	
17	KC6AWX	Bob	F	450	3077	1592	264	59	14	5006	32.5%	5/7/2013
18	KC7YE	Jack	F	-	-	-	-	-	-	0	0.0%	
19	KD5YUK	Billv	F	-	-	-	-	-	-	0	0.0%	
20	KD7KST	Bill	M/F	1792	-	-	-	-	-	0	0.0%	9/30/2012
21	KF7PKL	Davis	F	379	879	211	48	15	1	1154	7.5%	10/9/2013
22	KG5RJ	Greg	F	606	3049	2079	559	192	62	5941	38.6%	10/2/2013
23	KM1C	Bill	F	-	-	-	-	-	-	0	0.0%	
24	KU4YM	Dave	F	30	2782	29	10	2	1	2824	18.4%	9/6/2013
25	KM6HB	Mark	F	714	3077	2936	694	87	1	6795	44.2%	2/3/2013
26	NOKV	Barry	M/F	445	3077	3026	2257	312	66	8738	56.8%	10/4/2013
27	NOLXJ	Sharon	M/F	1361	3077	2263	1208	472	236	7256	47.2%	11/27/2013
28	N1API	Al	F	499	3077	1755	396	198	118	5544	36.0%	11/24/2013
29	N3HOO	Ed	F	-	-	-	-	-	-	0	0.0%	
30	N4JT	Jim	F	736	3077	3064	743	235	150	7269	47.2%	10/21/2013
31	N5MLP	Ron	M/F	391	3077	409	54	37	9	3586	23.3%	5/19/2013
32	NP6DB	Dennis	M/F	664	3077	2768	745	420	305	7315	47.5%	8/27/2013
33	N8CIJ	Dick	F	676	3077	3014	668	303	229	7291	47.4%	9/5/2013
34	N8HAM	Jim	I	0	3077	0	0	0	0	3077	20.0%	4/2/2013
35	N9WNN	Steve	F	0	2180	0	0	0	0	2180	14.2%	2/24/2013
36	NA8W	Darl	F/M	579	3022	852	381	212	99	4566	29.7%	9/12/2013
37	NF0N	Mike	F	785	3077	3077	915	108	50	7227	47.0%	12/31/2012
38	NN9K	Pete	F	816	3077	859	78	1	0	4015	26.1%	3/23/2012
39	NTZA	Gene	F	-	-	-	-	-	-	0	0.0%	
40	NU4C	Paul	F	-	-	-	-	-	-	0	0.0%	
41	NW6S	Jim	F	722	3077	3077	743	59	35	6991	45.4%	9/7/2013
42	NX4W	Lloyd	M/F	1135	3077	1274	436	290	97	5174	33.6%	7/27/2013
43	W0NAC	Matt	M/F	1807	3077	2827	1964	1075	425	9368	60.9%	11/27/2013
44	W3DLM	Don	F	359	3077	2390	298	101	55	5921	38.5%	10/12/2013
45	W4HI	Garv	F	-	-	-	-	-	-	0	0.0%	
46	W4SIG	Kerry	F	-	-	-	-	-	-	0	0.0%	
47	W4YDY	Dave	F	876	3077	3077	1035	353	175	7717	50.2%	9/5/2013
48	W5QP	Rick	M/F	244	3077	2598	252	113	83	6123	39.8%	10/6/2013
49	W6RK	Risto	F	-	-	-	-	-	-	0	0.0%	
50	W6RLL	Joe	F	-	-	-	-	-	-	0	0.0%	
51	W7FEN	Larry	F	25	3077	2975	32	1	0	6085	39.6%	10/3/2013
52	W7IN	Larry	F	-	-	-	-	-	-	0	0.0%	
53	W7QQ	Bill	M/F	-	-	-	-	-	-	0	0.0%	
54	W9JR	Rich	F	90	3077	1674	44	0	0	4795	31.2%	10/31/2012
55	W9SUQ	Larry	F	-	-	-	-	-	-	0	0.0%	
56	WA4EEZ	Leslie	F	1053	3077	1420	572	153	21	5243	34.1%	9/6/2013
57	WA4UNS	Doug	F	-	-	-	-	-	-	0	0.0%	
58	WA6OCV	Susan	M/F	328	3077	328	320	130	10	3865	25.1%	3/28/2013
59	WA7JHQ	Sterling	F	-	-	-	-	-	-	0	0.0%	
60	WB0M	Jeff	F	-	-	-	-	-	-	0	0.0%	
61	WB2ABD	Paul	F	-	-	-	-	-	-	0	0.0%	
62	WD4OIN	Jack	F	790	3077	3069	734	242	123	7245	47.1%	11/4/2013
63	WQ7A	Terry	F	201	3077	3028	206	132	112	6555	42.6%	8/24/2013
64	WY4D	Ben	F	265	3077	287	36	15	9	3424	22.3%	11/21/2013

As you can see, the table is gradually filling up with more people reporting their status.

### How To Get Your 5 – Mode Statistics Updated:

In the past two Digital Happenings articles I have given detailed instructions on a new and easy way to update your digital statistics for Table 3 by using a small program called “Digital Report Utility”. This new program will create a report for you showing your progress for both the **USA – Digital** and the **5 – Mode Awards**. Here is a sample screen shot of a typical report using NOKV’s (Barry’s) database:

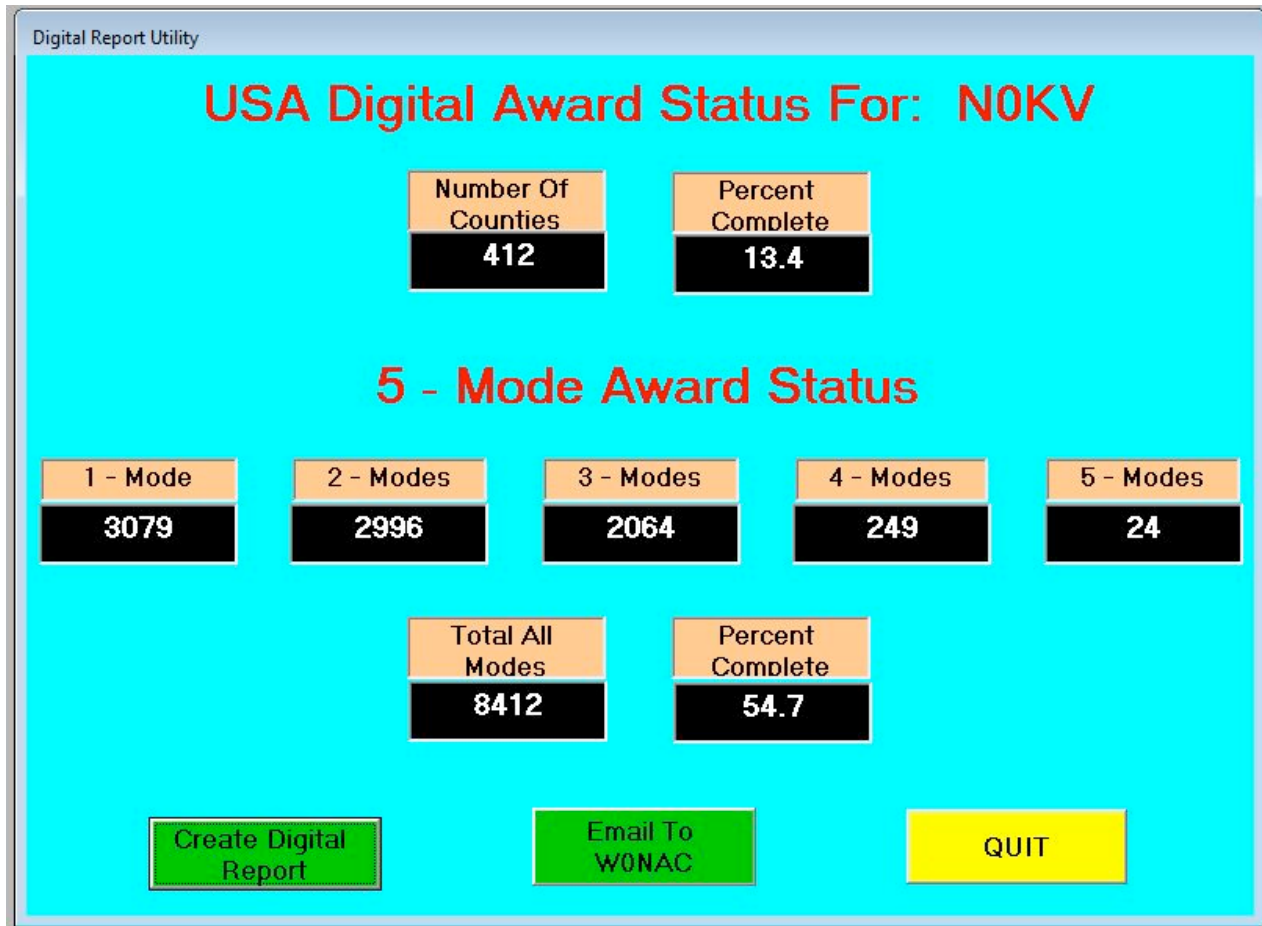

Once your own report is showing on your screen and you are OK with the numbers, the program can also email your statistics to me so I can update Table 3. There is no longer a need for anyone to manually extract their statistics.

If you would like to use this new utility, download the file “**Install Digital Report Utility Version 0.1.9.exe**” from the MARAC Server ( <http://www.marac.org/chdownloads> ). You may save this file anywhere you wish on your computer (desktop, download folder, etc.) because it is not sensitive to location. Running this file will install the new utility program in the proper folder (Program Files or Program Files (x86)) and place an icon on your desktop that you can use to run it. Once the new program has been installed, you can delete the install file if you wish.

**Please Note:** When you first run the new program you need to make sure that it points to your call sign database file (files if you are an OM/YL team). This file(s) will usually be found in your “C:\Logger Data” folder.

To point the program to your file(s), press F-10 while on the opening screen. Please see past articles for more detailed instructions if you need them.

Since it is nice and easy now, I encourage everyone listed on the table to use the new utility to email me current statistics NLT December 27<sup>th</sup> so I can update the table with your information. If there is anyone not listed in Table 3 who would like their statistics included, just run the utility and have it email your numbers to me. I will get you listed!

**Caution:** The email portion of this program may not work with every email client out there, especially web based email clients. If that part doesn’t work for you, just include your numbers in an email that you create manually using your own email client and send it to [w0nac@comcast.net](mailto:w0nac@comcast.net) . Many Thanks!



Possible topics for the coming months include (in no particular order):

**“New JT65 and JT9 Software”**

**“How To Log Your Digital Contacts In Logger”**

**“Macros – Revisited”**

**“New Digital Awards?”**

**“Digital Software Installation – Revisited”**

**“Award Difficulty Index”**

As always, I still need (and welcome) your suggestions on topics for future articles! Or if you have something you wish to contribute I will certainly try to include it. Short stories describing your experiences/frustrations/etc. in getting started in digital ops would be especially welcome. Summaries of your digital trips would also be good. I look forward to hearing from you.

Please email me with your comments/suggestions at [w0nac@comcast.net](mailto:w0nac@comcast.net) and don't forget to send me your updated status for the **USA – Digital** and **5 - Mode Awards** so I can update the Active Digital County Hunters Award Status list again next month.

73's and we hope to see you on our waterfall again real soon!

Matt – W0NAC



Calendar

~ December 2013 ~						
Sun	Mon	Tue	Wed	Thu	Fri	Sat
1	2	3	4	5	6 ARRL 160M CW	7
8 10M RTTY STRT KEY SPRINT CO SNOWSHOE	9	10	11	12	13	14 ARRL 10M
15	16 RUN4BACON	17	18	19	20	21
22 ARRL ROOKIE CW	23	24	25	26	27	28
29	30	31	<p>Notes: ONLY START DATE SHOWN. CLICK ON EVENT TO GO TO WEB SITE.</p> <p>JAN 1 IS STRAIGHT KEY NITE</p>			





**Treasurer's Report (WONAC)  
October 2013\***

Beginning Account Balances Oct 4, 2013		<b>\$36,563.36</b>
October Income:		
Money Market Interest	\$2.81	
Awards Manager Income	\$869.00 #	
Membership Income	\$278.89	
Logger distribution	\$25.00	
Total Income:		<u>\$1,175.70</u>
October Expenses:		
Awards Manager Expenses	\$132.17 #	
Marsh – Annual Liability Insurance	\$396.00	
Office Expenses	\$0.00	
Total Expenses:		<u>\$528.17</u>
October Special Distributions:		
Seed Money For 2014 National	\$4,000.00	
Total Distributions:		<u>\$4,000.00</u>
October Net Income Less Expenses & Distributions		<b>(\$3,352.47)</b>
New Total Balance ALL Accounts:		<b>\$33,210.89</b>
Checking Account Balance	<u>\$2,178.21</u>	
Money Market Account Balance	<u>\$31,032.68</u>	
Total:		<b>\$33,210.89</b>

## Note:

The following monies are not included in the account balances above:

Awards Chairman's Funds	\$1,500.00
2014 National Convention Seed Monies	\$4,000.00 (Some will be expensed later)

\* Includes October Transactions through 11/4/2013

# Combined September/October Awards Manager Income/Expense.



MARAC National

46th Annual National Convention 2014 Registration

July 9 – 12 Visalia, California

(Deadline for Early Registration Prize Drawing is May 1, 2014)

NAME: (First Mi, Last) \_\_\_\_\_

ADDRESS: \_\_\_\_\_

CITY \_\_\_\_\_ ST/PROV \_\_\_\_\_ POSTAL CODE \_\_\_\_\_

Convention registration fee: **\$ 45.00**

(One registration fee/family unit – Includes 1 prize ticket & 1 group photo)

NAME ON BADGE \_\_\_\_\_ CALLSIGN \_\_\_\_\_ USACA# \_\_\_\_\_

Additional Name Badges (list information below) Total # \_\_\_\_\_ @ \$5.00 each = \$ \_\_\_\_\_

Name \_\_\_\_\_ Callsign \_\_\_\_\_ USACA# \_\_\_\_\_ Relation \_\_\_\_\_

Name \_\_\_\_\_ Callsign \_\_\_\_\_ USACA# \_\_\_\_\_ Relation \_\_\_\_\_

Relation: W-Wife, H-Husband, D-Daughter, S-Son, M-Mother, F-Father, X-Friend, GD-Grand Daughter, GS-Grand Son, for any additional badges please attach or list on back of form.

*Enter number of persons that will attend events*

**Wednesday 09 July – Check-In/Do It Yourself Activities**

**Thursday 10 July**

If enough interest a Bus will come to the hotel, free of charge and transport a group to the nearby Indian Casino, please check here if interested \_\_\_\_\_

**Friday 11 July (Tour below is limited to Max of 30 People)**

Sequoia National Park – Depart 8:00/9:00 AM (2 buses 15 each) #Adults \_\_\_\_\_ X \$35.00 = \$ \_\_\_\_\_

**Saturday 12 July**

Banquet – **San Joaquin Buffet**

Mixed Field Green Salad with assorted Dressings

Pasta Salad with Bay Shrimp, Red Onions, Red and Yellow Bell Peppers

Platter of Sliced Fresh Fruit and Berries

Grilled Balsamic Vegetable Platter with Fresh Mozzarella Cheese

Braised Breast of Chicken in Red Wine Sauce with Pancetta and Pearl Onions

Charbroiled Salmon Medallions on Bed of Sautéed Spinach, Dill Herb Sauce

Rice Pilaf, Roasted Red Potatoes

#Adults \_\_\_\_\_ X \$45.00 = \$ \_\_\_\_\_

**Additional Prize Tickets**

Prize (Singles) \_\_\_\_\_ X \$ 1.00 = \$ \_\_\_\_\_

Prize (Book 12 tickets) \_\_\_\_\_ X \$10.00 = \$ \_\_\_\_\_

Cash (singles) \_\_\_\_\_ X \$ 1.00 = \$ \_\_\_\_\_

Cash (Book 12 tickets) \_\_\_\_\_ X \$10.00 = \$ \_\_\_\_\_

**Photographs**

Extra: \_\_\_\_\_ X \$10.00 = \$ \_\_\_\_\_

YL: \_\_\_\_\_ X \$10.00 = \$ \_\_\_\_\_

USA-CA: \_\_\_\_\_ X \$10.00 = \$ \_\_\_\_\_

CW: \_\_\_\_\_ X \$10.00 = \$ \_\_\_\_\_

DATA: \_\_\_\_\_ X \$10.00 = \$ \_\_\_\_\_

**Total Amount Enclosed:** \$ \_\_\_\_\_

Mail Registration Form and Check to – Robert Devine (KC6AWX) [Home Phone 1-415-883-8980]

(Make check payable to “MARAC”, 407 Alameda Del Prado, Novato, CA 94949

Hotel Reservations – MARAC (MAR)

## WA4EEZ

Leslie Johnson WA4EEZ, USA-CA #1236  
August 5, 2013



Leslie Johnson, WA4EEZ, completed her USA-CA Award 51 years after beginning to collect counties!

Ameco Code Records—remember those? My OM, K4SHI, was listening to them back in 1961 after he came home from work. While he worked on his code, I would be cooking dinner, so I couldn't help but hear all those dits and dahs. Before long, I knew the code fairly well (at least to copy it!) and shortly afterward, I took the Tech and Novice tests. In December 1961, I became WN4EEZ and WA4EEZ at the ripe old age of 17. I became very active on the VHF bands; made many, many contacts; got my CW speed up with my J-38 on the Novice bands; participated in a Field Day; and even stood by on a local emergency net with Nancy, WA4EDL, during the Cuban Missile Crisis.

Before long, I got some QSL cards returned, and noticed that I had worked different states and counties—the Florida Skip Magazine offered a "Worked all Florida Counties" award, so I kept that in mind as I worked along. (Note: The Worked All Florida Counties Award is now administered by The Florida Contest Group) The Clegg 99'er (8 watts) and Globe Hi-Bander 6n2 (50 watts) were two rigs I used in those early days. I built a Heathkit HX-11, which I enjoyed building AND using! I even got into the CQWW VHF contest in 1963 and got a nice certificate for "High Scorer" in the "Florida" section. Somewhere in there, however, a hurricane

came along and took down my beloved Finco 6n2 beam. I was off the air until 1977, when I got my General license and put up a vertical for HF. Unfortunately, shortly afterward we got two lightning hits that destroyed most all of our ham gear. I became busy with work and family until 1999, when a couple of our ham friends insisted on helping us get back on the air.

Wow—10m was hopping and I was hooked all over again!! Managed to confirm 500 counties on 10m for the USA-CA-500 award. When the sunspots disappeared, I migrated to HF; began learning about the digital modes—PSK, Hell, RTTY; got into some of the smaller contests and began to see a steady increase in my county total. However, I didn't really believe I could ever get them all—but thought maybe 1000 might be doable. Gosh, maybe even 2000. By this time I was using an Icom 756 Pro II at 100 watts, and all wire antennas for 80-10m.

One fine day in late 2004, I came across the CHN (County Hunters' Net) on 14.336 MHz and began to work on my counties a bit more diligently! I had maybe 1100 counties by then. I learned how to make out the MRCs and use the MARAC QSL Manager service. Hey, this is the way to go!

The final impetus for my county-hunting came when I attended the memorial service for Wendy, KB1AF. She was a member of our local club, and a truly delightful person. She had been very active on the airwaves here locally, despite many health issues. At her service, her USA-CA 3077 Number 952 was displayed, and I determined at that moment to try for all 3077 counties in Wendy's honor.

I continued collecting counties passively, using ragchews and contests and got back onto the CHN's pretty much full time in 2011, when I came across the 40m CH folks on 7.188....Scottie, N4AAT and Joe, N5UZW helped me get started again, and the chase was on! Before too long, using various bands and modes, I had about 1500, then 2500, and then 3000 counties confirmed....

The last three counties seemed to take forever (although it was less than a month, actually). Petroleum, MT—Benton, OR—and Traverse MN. Petroleum County, MT was being run by two mobiles at the same time—WQ7A/m on 20 SSB, and N4CD/m on 20m CW...what to do?...somehow I managed to work them both at 1805z. WQ7A got Benton, OR for me and that left ONE to go! Thanks to Brian, NX0X and his XYL Shari, KB0MHH, Traverse MN—Number 3077 is in the log!

My heartfelt gratitude to all the mobiles, net control stations, contesters, ragchewers, and card checkers who helped me so much along the way! It has taken me 51 years—what a fantastic journey!

73 and good hunting! Leslie, WA4EEZ

**Awards Committee**

**These MARAC members are serving on the Awards Committee:**

**Awards Manager - Bob Devine (KC6AWX)**

**Phil Yasson ( AB7RW )**

**Bob Gedemer ( KA9JAC )**

**Dave Splitt ( KE3VV )**

**Kent Reinke ( KV7N )**

**Ed Palagyi ( KN4Y )**

**“Matt” Matthew (W0NAC)**

**David Pyle ( KW1DX))**

*The County Line Roadrunner*  
**MARAC Secretary**  
**2690 Bohicket Rd**  
**Johns Island, SC 29455**

*“A Road Runner Is A Very Fast Bird”*

**Monthly Deadline for Articles is the 25<sup>th</sup>!**

---

**Board of Directors**

**President:** David Splitt, KE3VV, 6111 Utah Ave NW, Washington DC 20015, 301-300-2818, [davidsplitt@erols.com](mailto:davidsplitt@erols.com)

**Vice-President:** Leo Bingham, WY7LL, (SK)

**Secretary:** Jim Grandinetti, KZ2P, 2690 Bohicket Rd, Johns Island, SC 29455, 843-323-8385, [k2jg@comcast.net](mailto:k2jg@comcast.net)

**Treasurer:** Matt Matthew, W0NAC, 17525 Wilde Ave, Unit 108, Parker CO 80134, 303-941-0867, [w0nac@comcast.net](mailto:w0nac@comcast.net)

**Great Lakes Director:** Dan Mulford, KM9X, 5225 N Co Rd 100E, Osgood IN 47037, 812-498-6702, [km9x@frontier.com](mailto:km9x@frontier.com)

**North Central Director:** Tony Mazzocco, WA9DLB, 275 E County Line RD, Barrington, IL 60010, 224-678-5265, [wa9dlb@hotmail.com](mailto:wa9dlb@hotmail.com)

**Northeast Director:** Carol-Ann Reitman, AB2LS, 100 Woodbury Rd, Highland Mills, NY 10930, 845-928-6238, [ab2ls@optonline.net](mailto:ab2ls@optonline.net)

**South Central Director:** Barry Mitchell, N0KV, 12200 Boothill Dr, Parker, CO 80138, 303-842-5635, [n0kv@arrl.net](mailto:n0kv@arrl.net)

**Pacific Director:** Robert T. Devine, KC6AWX, 407 Alameda Del Prado, Novato, CA 94949-6302, 415-883-8980, [kc6awx@marac.org](mailto:kc6awx@marac.org)

**Southeast Director:** Kerry Long, W4SIG, 1385 Auburn Woods Dr, Collierville TN 38017, 901-331-1881, [kerrylong@comcast.net](mailto:kerrylong@comcast.net)

**Immediate Past President:** Joyce Boothe, WB9NUL, 21175 FM2556, Santa Rosa, TX 78593 1-956-202-3373, [joycenul@aol.com](mailto:joycenul@aol.com)

**Awards Manager:** Robert T. Devine, KC6AWX, 407 Alameda Del Prado, Novato, CA 94949-6302, 1-415-883-8980, [kc6awx@marac.org](mailto:kc6awx@marac.org)

**Appointees**

**Historian:** Gary Beam, K4EXT, 195 Nanny Goat Hill Rd, Elizabethton, TN 37643, [ch2@k4ext.com](mailto:ch2@k4ext.com)

**Newsletter Editor:** Dave Hyatt, KU4YM, 159 Schooler Bend Ave, Summerville, SC 29483, 843-442-8666, [dhhyatt@ieee.org](mailto:dhhyatt@ieee.org)

**Sunshine Coordinator:** Pat Reiner, KM6QF, 16931 Aldon Rd, Encino, CA, 91436, 213-999-0100, [lovedoxies@aol.com](mailto:lovedoxies@aol.com)

**Webmaster:** Mike Fatchett, W0MU, PO Box 3500, Parker, CO 80134, 303-790,4611, [w0mu@w0mu.com](mailto:w0mu@w0mu.com)

**Custodian, Club Call, K9DCJ:** Joyce Boothe, WB9NUL, 21175 FM2556, Santa Rosa, TX 78593 1-956-202-3373 [joycenul@aol.com](mailto:joycenul@aol.com)

**Election Coordinator:** Kent Reinke, KV7N, 1826 East 4500 North, Buhl ID 83316, 208-543-6083, [kr@gci.net](mailto:kr@gci.net)

**MARAC General Counsel:** David Splitt, KE3VV, 6111 Utah Avenue NW Washington, D.C. 20015-2461, 1-202-362-3355, [ke3vv@marac.org](mailto:ke3vv@marac.org)

**Computer Data Manager:** Gene A Olig Sr, KD9ZP, W 4325 4th St Rd, Fond du Lac, WI 54937, 920-923-0130, [kd9zp@att.net](mailto:kd9zp@att.net)

Dues with an Electronic copy of the Newsletter copy are \$14.00 per year, check or money order; \$14.75 via PayPal.